



*Changes for the Better*

MITSUBISHI INDUSTRIAL ROBOT

**MELFA** RV-2SDB/RV-2SQB Series



**RV-2SDB/RV-2SQB**

Mitsubishi Electric Corporation Nagoya Works is a factory certified for ISO14001 (standards for environmental management systems) and ISO9001 (standards for quality assurance management systems)



<http://MitsubishiElectric.co.jp/melfansweb/english/>



# MELFA RV-2SDB / RV-2SQB Series Vertically Articulated Robot. A New Design that is Streamlined, Compact, High-Speed, with High Functionality and 2kg Payload

A compact 6 axis robot ideally suited for assembly, material handling, inspection, and a wide variety of other tasks.

## Features

### Reduced profile while maintaining a large operating range

- The length and shape of the arm are designed for optimum performance and maximum reach while providing the ability to reach positions close to the robot base.
- A greater range of motion is insured in applications requiring ceiling or wall mount.
- J1 operation range is expanded to 480° (±240°). This eliminates any rear side dead zone.

### Advanced servo control provides high-speed and high-accuracy operation

- Maximum composite speed is 4,400 mm/s. Additionally, the speeds of axes J4-J6 have been optimized to satisfy high-speed assembly applications.
- Positioning repeatability of ±0.02mm combined with active-gain control and highly rigid arm design provide for high accuracy positioning at high speed.

### Unique arm design allows greater range of motion and accessibility

- Offset arm design greatly reduces the robots minimum operating radius allowing work close to the robot base.
- Reduced elbow protrusion lessens rear interference points.
- A compact wrist design enables the robot to reach into smaller spaces at many angles.

### Multiple interfaces assure convenience and flexibility in integration

- The robot comes standard with additional axis control, Ethernet and encoder (for line tracking) interfaces. Profibus and DeviceNet are available options.
- \* SQ needs manual pulser input unit (Q173DPX) for line tracking.
- Direct communication to GOT is available without the use of a programmable controller.

### Software tools are powerful and user-friendly allowing simplified design, programming, monitoring and diagnostics

- RT ToolBox2 : Windows based software for robot programming, debugging, parameters, simulation and diagnostics.
- MELFA-Vision: Machine vision software configuration tool for Cognex In-sight vision sensors.
- MELFA-Works: Advanced 3-D simulation and design software that works as an add-on to SolidWorks.

## Robot Arm

### Quicker posture changes- ideal for assembly applications

Assembly work typically requires many postures compared to pick and place work.

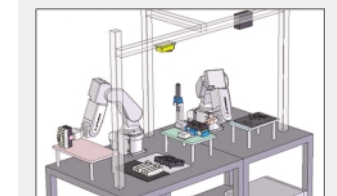

Assembly cell

Increasing the speed of posture change has a significant affect on overall cycle time. By optimizing the performance of axes J4-J6, posture change time is improved.

The speed of J4, J5, and J6 have improved by 10% compared to RV-3SD/SQ.

### Ability to layout the work cell with points near the robot base

Range of motion is now closer to the base of the robot. This allows more flexibility and smaller system footprint.



Layout is made more compact. Position/posture at minimum operating radius

The minimum radius becomes smaller by the offset arm design (139 mm compared to 319 for RV-3SD) However the overall operating range (R max-R min) is greater than RV-3SD at 365 mm vs.323 mm.

Increase space efficiency and the compact layout is possible.

### Large work area can be reached without rotating the arm

Extended back reaching access is effective for ceiling mount applications.

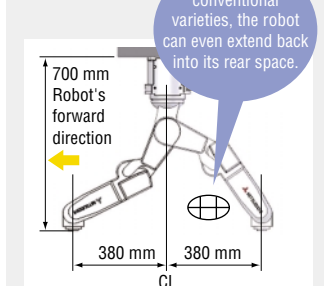

Expanded J2 operation range for extended back reach.

Wide work area can be secured without turning around the arm. Decrease extra motion, reduce the cycle time.

### The J1 operation range designed +/- 240 degree

Cycle time can be short if it is possible to take a short cut path.

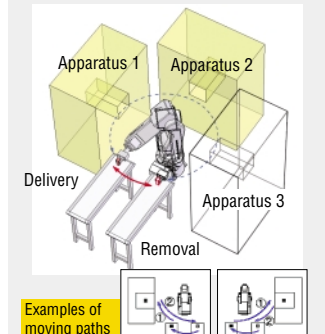

J1 operation range expanded to 480° (±240°).

Minimize path, Minimize cycle time. Decrease flexibility of machine layout.



## [Robot's Outer Dimensions and Operating Range]

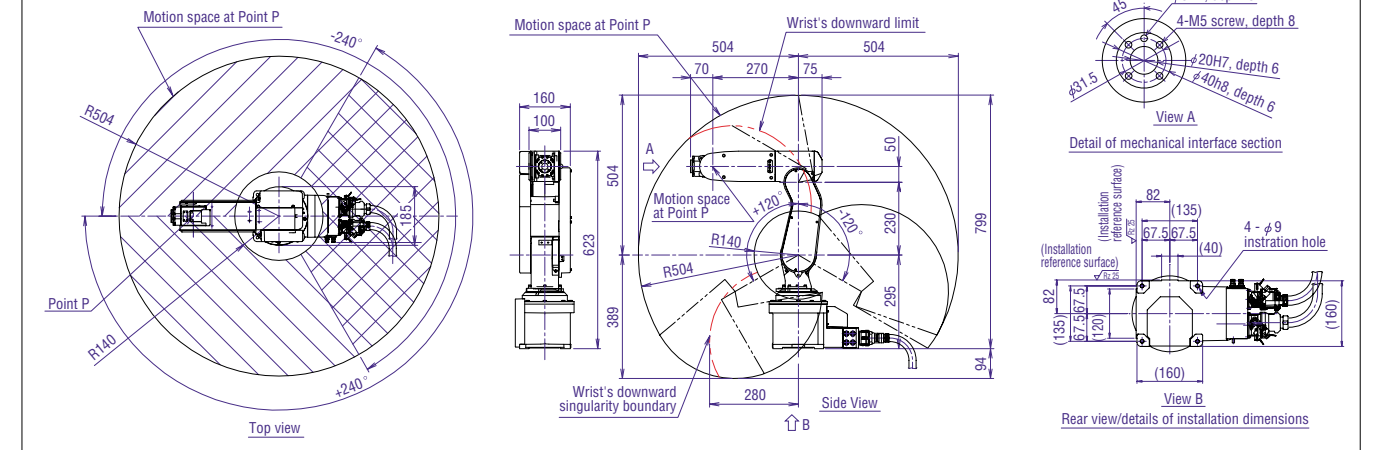

## Specifications

### Robot Arm

| Item                    | Unit     | Specification                                    |
|-------------------------|----------|--|
| Type                    |          | RV-2SDB / RV-2SQB                                |
| Protection class        |          | IP30   |
| Installation            |          | Floorstanding, ceiling-hung, and wall-mounted *1 |
| Structure               |          | Vertical articulated arm robot                   |
| Degrees of freedom      |          | 6  |
| Arm length              | mm       | 230+270  |
| Maximum reach radius    | mm       | 504  |
| Operating range         | J1       | 480 (-240 to +240)                               |
|                         | J2       | 240 (-120 to +120)                               |
|                         | J3       | 160 (0 to +160)                                  |
|                         | J4       | 400 (-200 to +200)                               |
|                         | J5       | 240 (-120 to +120)                               |
|                         | J6       | 720 (-360 to +360)                               |
| Maximum speed           | J1       | 225  |
|                         | J2       | 150  |
|                         | J3       | 275  |
|                         | J4       | 412  |
|                         | J5       | 450  |
|                         | J6       | 720  |
| Maximum composite speed | mm/s     | 4400   |
| Cycle time *3           | s        | 0.68   |
| Load                    | Rated    | kg 2.0   |
|                         | Capacity | Maximum kg 3.0 (wrist, downward)                 |
| Position repeatability  | mm       | ±0.02  |
| Mass                    | kg       | 19   |

\*1 There are limits to J1 motion when wall-mounted.  
\*2 All axes are equipped with a brake.  
\*3 Value at a load of 1kg when the robot reciprocates 25mm vertically and 300mm horizontally.

### Controller

| Item                     | Unit                               | Specification   | Remark                                       |   |
|--------------------------|------------------------------------|---|--|---|
| Type designation         |                                    | CR1DA-771 (RV-2SDB) CR1QA-771 (RV-2SQB)                         |  |   |
| Robot language           |                                    | MELFA-BASIC V   |  |   |
| Position teaching method |                                    | Teaching method, MDI method                                     |  |   |
| External input/output    | Input/output                       | Point 0 input / 0 output (maximum 256/256, available as option) | 8192 / 8192 (between sequencer and robot)    |   |
|                          | Dedicated input/output             | Point   | Assigned according to general-purpose I/O.   |   |
|                          | Input for shutdown purpose only    | Point   | 1  |   |
|                          | Hand open/close input/output       | Point   | 4 inputs / 0 output                          | 4 additional outputs are available as option. |
|                          | External emergency shutdown input  | Point   | 1  | Double-redundant                              |
|                          | Door switch input                  | Point   | 1  | Double-redundant                              |
|                          | Enabling device input              | Point   | 1  | Double-redundant                              |
|                          | Synchronization of additional axes | Point   | 1  | Double-redundant                              |
|                          | Mode output                        | Point   | 1  | Double-redundant                              |
|                          | Error output                       | Point   | 1  | Double-redundant                              |
| Interface                | RS-232                             | ports 1   | Extensions for computer, vision sensor, etc. |   |
|                          | RS-422                             | ports 1   | I/F dedicated to TB                          |   |
|                          | Ethernet                           | ports 1   | 1 (dual-use, user and TB)                    | 10BASE-T / 100BASE-TX                         |
|                          | USB                                | ports 1   | 1  | Device function only, mini-B terminal         |
|                          | Additional-axis I/F                | channels 1  | 1  | SSCNET III                                    |
|                          | Tracking I/F                       | channels 1  | 1  | For connecting encoder cable                  |
|                          | Slot for hand                      | slots 1   | 1  | Slot dedicated to air hand I/F                |
|                          | Extension slot                     | slots 1   | 1  | For installing optional I/F                   |
|                          | Input voltage range                | V   | Single phase, AC200 to 230±10% (180 to 253)  |   |
|                          | Power supply                       | KVA   | 0.5  | Not including in-rush current                 |
| Frequency                | Hz                                 | 50 / 60   |  |   |
| External dimensions      | mm                                 | 240(W) x 290(D) x 200(H)  | Protrusions excluded                         |   |
| Weight                   | kg                                 | Approx. 9   |  |   |
| Structure                |                                    | Self-contained floor type / open structure (IP20)               |  |   |
| CPU                      | Type designation                   | -   | Q172DRCPU IQ Platform-compliant              |   |

## SQ Series Controller - New Capabilities

### iQ platform compatibility-High speed communication and ease of integration

With the robot CPU mounted in an iQ system, communications between the sequencer or other available CPU's are much faster and at greater volumes. Total machine integration is simplified and performance is enhanced.

### GOT interface provides easy access to robot data and status

Shared memory across the iQ platform allows multiple sets of machine data to be easily accessed and displayed via GOT. This serves as a user-friendly system interface at a single point.

### Robot can be directly controlled from the sequence program

RV-2SQB programming flexibility comes with the ability to command the robot directly from the sequencer program. This method allows complete machine control with a single language. Traditional programming via MELFA-Basic V is also available.

### Direct sequencer control is possible

Not necessary to program in dedicated robot language

Programming can be accomplished directly within the sequencer language. No need to use a second language/program to control the robot.

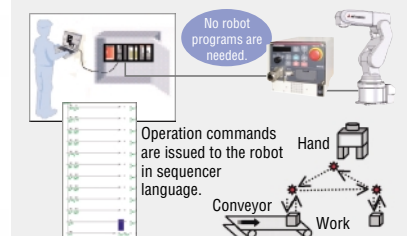

The ability to command the robot directly from the sequencer program.

Programming time can be reduced and integration can be simplified by using a sequencer language that you are already familiar with.

### Robot data can be easily accessed and displayed on GOT

Convenient monitoring and retrieval of information from robot and other machine components at a single point

Essential data from the robot can be displayed without referring to the robot program, editing software, or teach pendant.

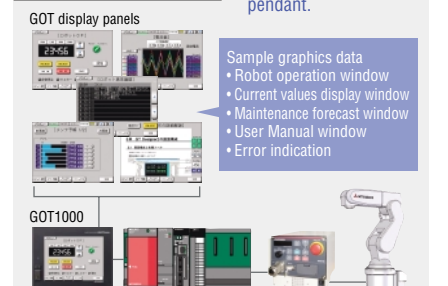

Various data is stored in a memory shared by sequencer multi-CPU's.

Sample GOT programs are available.

## Product Configuration

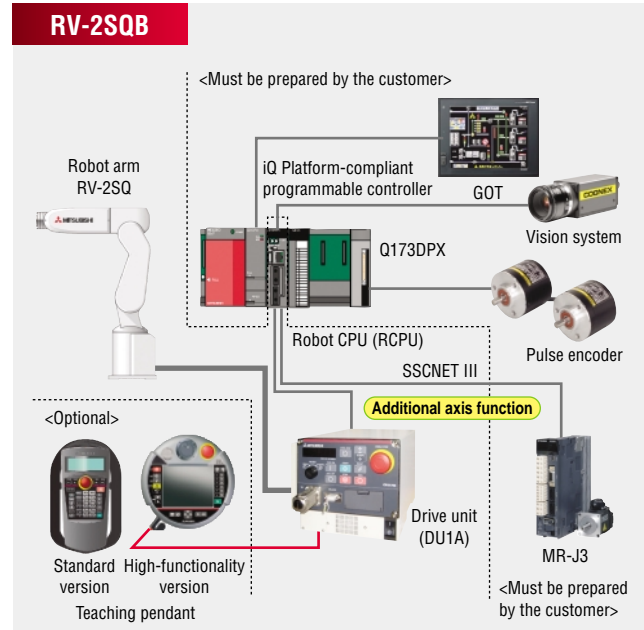
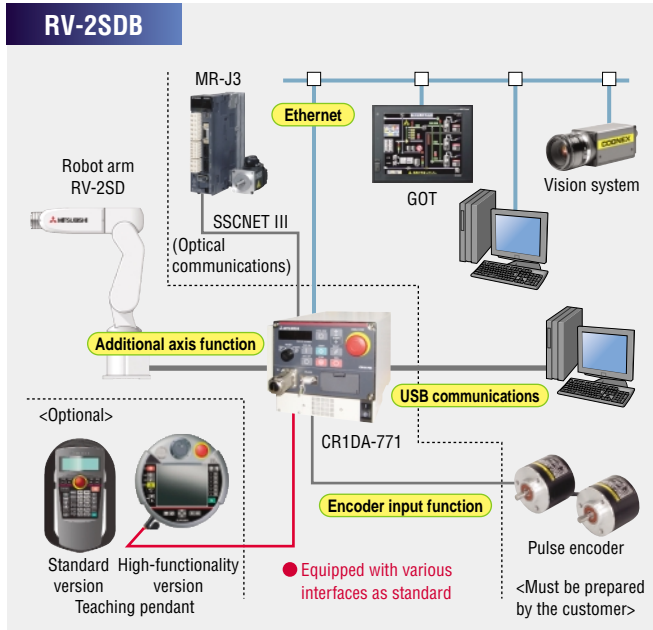

## Configurations Options

| Classification | Name                                    | Type                                  | Specification overview   | RV-2SDB                                     | RV-2SQB |   |
|----------------|---|---------------------------------------|--|---|---------|---|
| Robot arm      | Solenoid valve set                      | 1E-VD01/VD01E                         | Solenoid valve (with an output cable, 1 valve) (sink/source)             | ○   | ○       |   |
|                |   | 1E-VD02/VD02E                         | Solenoid valve (with an output cable, 2 valves) (sink/source)            | ○   | ○       |   |
|                | Hand output cable                       | 1E-GR35S                              | With a robot-side connector, not terminated at another end               | ○   | ○       |   |
|                | Hand input cable                        | 1S-HC30C-11                           | With a robot-side connector, not terminated at another end               | ○   | ○       |   |
|                | Hand curl tube                          | 1E-ST0402C                            | φ 4 tube, number of sets - 2   | ○   | ○       |   |
|                |   | 1E-ST0404C                            | φ 4 tube, number of sets - 4   | ○   | ○       |   |
|                | Stopper for changing operating range    | 1S-DH-11J1                            | For limiting J1 axis rotation (±210 deg., ±150 deg., ±90 deg.)           | ○   | ○       |   |
|                |   | 1S-DH-11J2                            | For limiting J2 axis rotation (±30 deg.)                                 | ○   | ○       |   |
|                |   | 1S-DH-11J3                            | For limiting J3 axis rotation (+70 deg.)                                 | ○   | ○       |   |
|                | Machine cable, for extension/fixd       | 1S-05CBL-03                           | Extension type: 5 m  | ○   | ○       |   |
|                |   | 1S-10CBL-03                           | Extension type: 10 m   | ○   | ○       |   |
|                |   | 1S-15CBL-03                           | Extension type: 15 m   | ○   | ○       |   |
|                |   | Machine cable, for extension/flexible | 1S-05LCBL-03   | Extension type: 5 m                         | ○       | ○ |
|                |   |                                       | 1S-10LCBL-03   | Extension type: 10 m                        | ○       | ○ |
|                | 1S-15LCBL-03                            |                                       | Extension type: 15 m   | ○   | ○       |   |
| Controller     | Teaching pendant, standard version      | R32TB                                 | 7 m: Standard / 15 m: Custom   | ○   | ○       |   |
|                | High-function teaching pendant          | R56TB                                 | 7 m: Standard / 15 m: Custom   | ○   | ○       |   |
|                | Air hand interface                      | 2A-RZ365/375                          | 8 output points, used exclusively for hand (sink/source)                 | ○   | ○       |   |
|                | Parallel I/O unit (remote)              | 2A-RZ361/371                          | 32 output points / 32 input points (sink/source)                         | ○   | ×       |   |
|                | External I/O cable                      | 2A-CBL05/2A-CBL15                     | Cable length: 5 m / 15 m, not terminated at one end (for 2A-RZ361/371)   | ○   | ×       |   |
|                | Parallel I/O interface (on-board)       | 2D-TZ368/378                          | 32 output points / 32 input points (sink/source)                         | ○   | ×       |   |
|                | External I/O cable                      | 2D-CBL05/2D-CBL15                     | Cable length: 5 m / 15 m, not terminated at one end (for 2D-TZ368/378)   | ○   | ×       |   |
|                | CC-Link interface                       | 2D-TZ576                              | CC-Link intelligent device station, Version 2.0, 1 to 4 stations         | ○   | ×       |   |
|                | PROFIBUS interface                      | 2A-RZ577                              | Slave station, combined total number of input and output data: 192 words | ○   | ×       |   |
|                | DeviceNet Slave interface               | 2D-TZ571                              | Slave station, Release 2.0 is supported                                  | ○   | ×       |   |
|                | Additional memory                       | 2D-TZ454                              | User program area with additional memory: 2MB                            | ○   | ×       |   |
|                | Personal computer support software      | RT-Toolbox2                           | With simulation function (CD-ROM)  | ○   | ○       |   |
|                | Personal computer support software-mini | RT-Toolbox2 Lt                        | Lite Version (CD-ROM)  | ○   | ○       |   |
|                | Personal computer cable                 | 2D-232CBL03M                          | For PC-AT compatible machine, 3 m  | ○   | ×       |   |
|                | MELFA-Vision                            | MELFA-Vision                          | COGNEX Vision System-compliant   | ○   | ○       |   |
|                | 3D simulator (MELFA-Works)              | MELFA-Works                           | Add-in to Solidworks software  | ○   | ○       |   |
|                | Service part                            | Backup battery                        | ER6  | Installed in the robot arm (Quantity: 4pcs) | ○       | ○ |
| Q6BAT          |   |                                       | Installed in the controller (Quantity: 1pc)                              | ○   | ○       |   |



HEAD OFFICE: TOKYO BUILDING, 2-7-3, MARUNOUCHI, CHIYODA-KU, TOKYO 100-8310, JAPAN

<http://Global.MitsubishiElectric.com/>